

MICROTECH MT-12 13B SEQUENTIAL ENGINE MANAGEMENT SYSTEM

MICROTECH MT-12 13B SEQUENTIAL

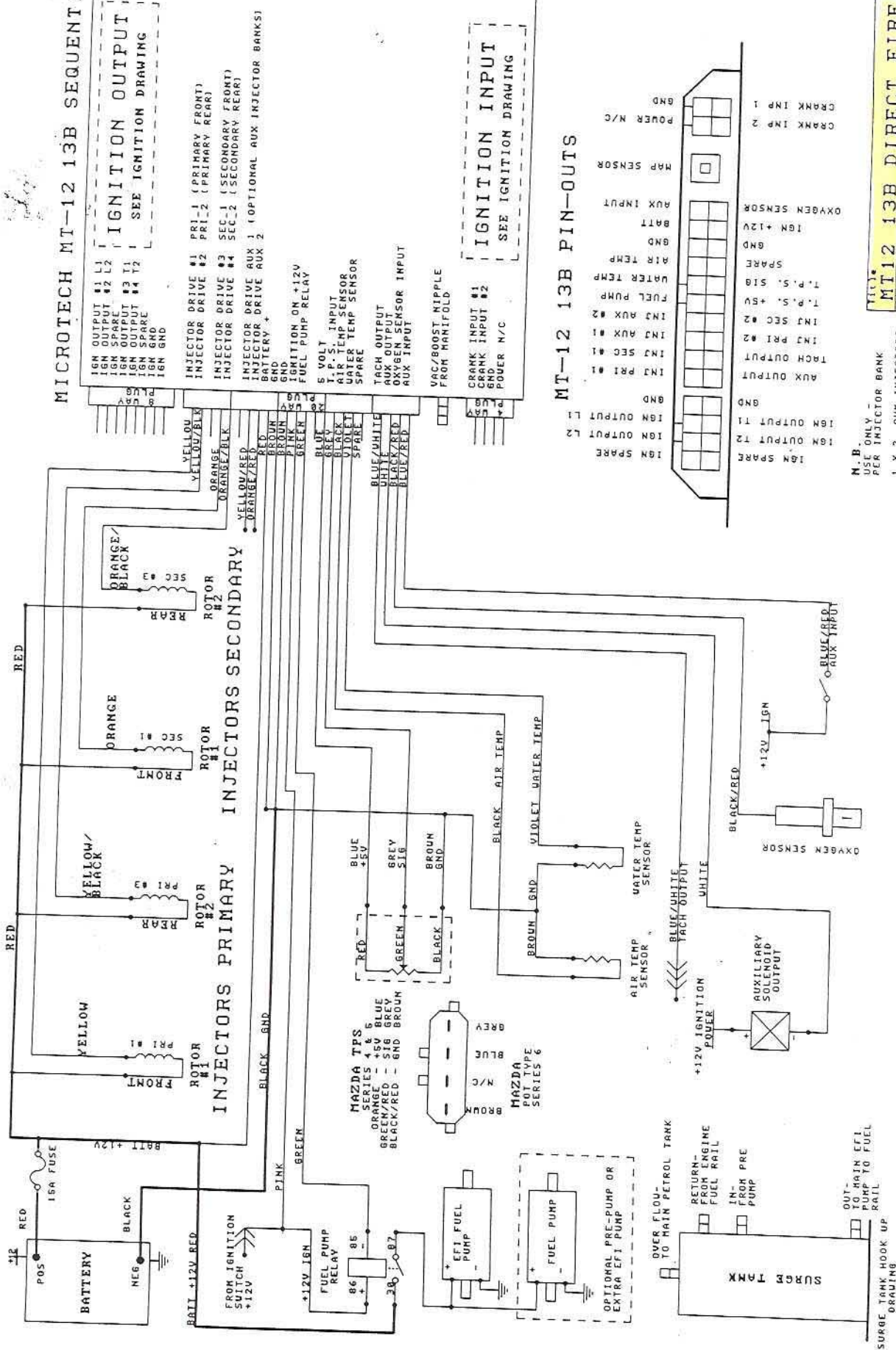

IGN OUTPUT #1 L1
IGN OUTPUT #2 L2
IGN OUTPUT #3 T1
IGN OUTPUT #4 T2
IGN SPARE
IGN GND

INJECTOR DRIVE #1 PRI-1 (PRIMARY FRONT)
INJECTOR DRIVE #2 PRI-2 (PRIMARY REAR)
INJECTOR DRIVE #3 SEC-1 (SECONDARY FRONT)
INJECTOR DRIVE #4 SEC-2 (SECONDARY REAR)
INJECTOR DRIVE AUX 1 (OPTIONAL AUX INJECTOR BANKS)
INJECTOR DRIVE AUX 2
IGN TERY +

IGNITION ON +12V
IGN GND
FUEL PUMP RELAY
5 VOLT
T.P.S. INPUT
AIR TEMP SENSOR
WATER TEMP SENSOR
SPARE
TACH OUTPUT
AUX OUTPUT
OXYGEN SENSOR INPUT
AUX INPUT
VAC/BOOST NIPPLE
FROM MANIFOLD

CRANK INPUT #1
CRANK INPUT #2
IGN GND
POWER N/C

MT-12 13B PIN-OUTS

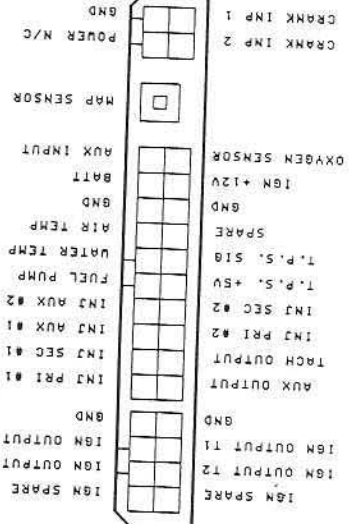

N.B.
USE ONLY -
PER INJECTOR BANK
1 X 2 OHM INJECTORS
2 X 2 OHM INJECTORS
3 X 2 OHM INJECTORS
4 X 12 OHM INJECTORS

TITLE
MT12 13B DIRECT FIRE
Number MAZDA 13B
Size 03
Revision 1.0
DRAWING
Sheet 1 of 2
Drawn By. DCH
8